



Conveyor
Application
Systems

FAT BOY



KNIFE REAR-GATE

Two years of research, development AND customer input, combined with innovative features, have led us to the introduction of *Conveyor Application Systems' (CAS®) new FAT BOY Slinger Truck!*

CAS® broke the Slinger Truck mold with the new *patent pending Fat Boy Slinger Truck design.*



CAS® QUALITY

All CAS® Slingers are made in the U.S.A.

- The on-road CAS® Fat Boy is the **ONLY** slinger Truck to proudly wear the designation, **Made in the USA.** With manufacturing and service facilities in Indianapolis, IN and Eugene, OR, which is where CAS® Slingers have been manufactured since 2004, CAS® locations are strategically located to support our customers.

SLINGER INNOVATION

- More capacity than **ANY SLINGER TRUCK** in the industry.
- Lower center of gravity for a safer and smoother ride.
- Vertical Walls and Horizontal Floor minimizes bridging.



FAT BOY DURABILITY

- Exclusive Trout River® Slinger box with a Hardox® 400 steel inner layer for durability.
- CAS® HD Select, abrasive & wear resistant, Placer and Feeder Belts.
- HD Feed Conveyor Chain with over 42 -tons of pulling strength.

CAS® PERFORMANCE

- Widest Placing Conveyor Belt provides up to 30% more Sliding volume.
- Optional 1' of additional side rail height for increased capacity.
- Two-way rear gate for Full Dump capabilities.

“ *The Fat Boy is not only the coolest looking Slinger Truck on the market, it has raised the bar so high, that anything else will be a distant second.*

“ *The coolest looking most efficient Slinger Truck on the market today!*

CAS® Slingers do the work, so you don't have to!



Conveyor Application Systems



888-279-4227



www.slingers.com

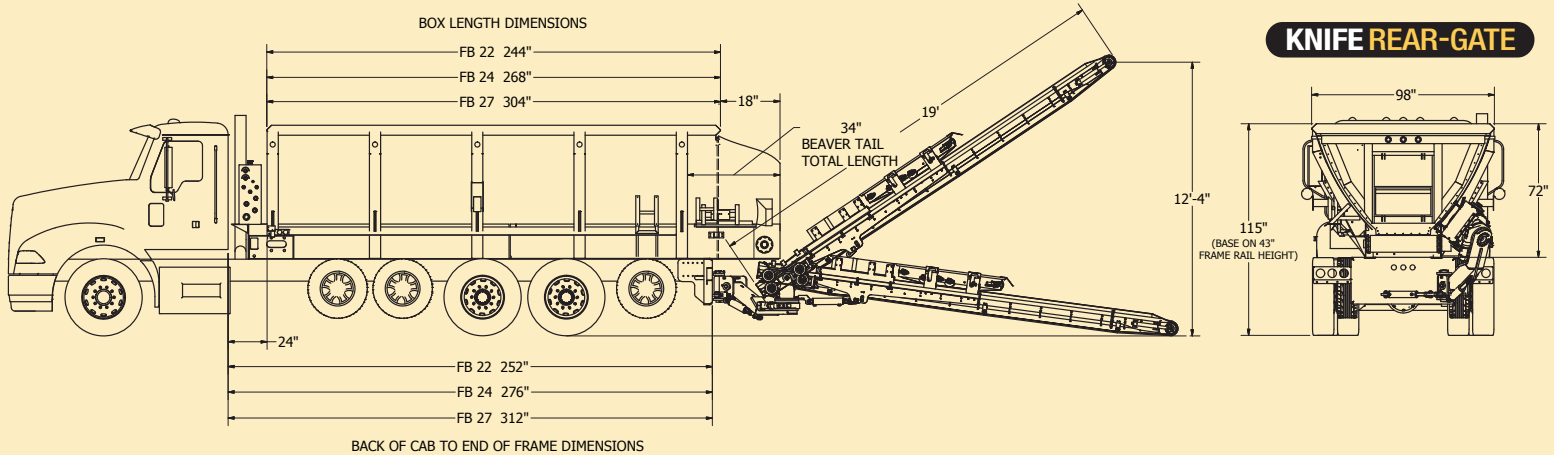

CHASSIS AND FRAME:

- Chassis is customer specified

Fat Boy Models-

- FB22: 22 Cubic Yards
- FB24: 24 Cubic Yards
- FB27: 27 Cubic Yards
- • Optional 1' of side rail height available. Adds 6-8 cubic yds.

HOPPER BODY:

- **ONE OF A KIND:** Triple Walled Trout River™ Steel Box
- Inner layer of HARDOX™ 400 steel for maximum durability!
- Insulated middle later for colder climates and/or asphalt operation.
- Stainless Steel or Aluminum outer shell keeps the body looking good after many hours of use.
- **Nearly Vertical Side Rails and Horizontal Floor** significantly reduces the opportunity for bridging.
- **Hydraulically Powered Tailgate w/Electric Controls:** 2-Way Gate (opens 90 deg.) with Full-Dump capabilities.
- Access Ladder, LED Lighting System w/Rear Safe Strobe Light
- Tarp Option: Electric Cable or Swing Arm System with integrated 12" Tarp landing.
- Fenders: Steel or Aluminum.

FEED CONVEYOR:

Heaviest Duty Feed Belt available combined with a HARDOX™ 400 steel inner layer, makes for the most durable combination in the industry!

- **Heavy-Duty 34" Impact & Abrasive Resistant Belt** with 0-degree incline for less wear.
- 32" of Full Exposed movable floor that is fully speed adjustable and can handle the widest range of materials.
 - More exposed belt means **MORE PULLING POWER** with less opportunity for bridging.
 - **Industry Leading Horizontal Floor Increases Pulling Power and Decreases bridging.**
 - Asphalt rated (*Asphalt liner required*)
- Forward & Reverse Control w/ HD 3" Pitch RS-3415 Chain: **84,000 lbs. Pulling Strength**
 - Chain Lubrication System- Reduces Maintenance & Extends Life

DIMENSIONS:

- **FB22: Capacity: 22 Yds., 22.5' Long x 6' High x 8.16' Wide**
 - **FB24: Capacity: 24 Yds., 24.5' Long x 6' High x 8.16' Wide**
 - **FB27: Capacity: 27 Yds., 27.5' Long x 6' High x 8.16' Wide**
- Increase Capacity! All Fat Boy Slingers can add an additional 1' of side rail height for 6-8 yards of additional capacity.*

PLACING CONVEYOR:

- **CAS® Exclusive HD 16" Wide Long Shot, Abrasive & Impact Resistant Surfaced Belt w/ 1/2" Cleats**
- The CAS® Belt is the heaviest duty and most durable belt on the market with 50% more rubber on the cleats.
- New Wider belt means a 20-30% increase in Slinging volume and greater versatility of materials.
- Hydraulic Drive Super Shield™
- Round Tube Steel Design
- High Performance Rear Mounted Direct Drive
- **Patented** Worm Gear Pivot
- PC Specifications:
 - FPM: 4,274-4,466
 - MPH: 47-50
 - "Slinging" distance: 120-130'
 - Volume: 2-4 yds. per minute
 - *Dependent upon material size and type.*



HYDRAULIC SYSTEM:

- PTO Mounted 5000 PSI Rated Load Sensing Hydraulic Piston Pump, integrated with a 3500 PSI Rated Gear Pump.
- Sauer Danfoss Hydraulic Motors
- Pressure & Return Filtration System
 - Pressure Filter Rating= 10 Microns
 - Return Filter Rating= 3 Microns
- HAWE Proportional Valves
- High Pressure Hoses & Fittings- 2,000-6,000 PSI
- 4:1 design factor and industry rated specifications meeting established industry standards for "Burst" pressure.

ELECTRICAL SYSTEM (12 or 24 VDC):

- OMNEX Radio & Receiver Control Package
- Remote Control/Wireless Placing Control Function
 - Frequency Hopping Spread Spectrum Technology (FHSS)
 - 900FT @ 2.4GHz, frequency Hopping @ 50 non-overlapping channels in 100kHz intervals (100,000 times per second)

OPTIONAL EQUIPMENT:

- **Chassis & Frame-**
 - Drive System: Remote Control/Wireless
- **Hopper Body-**
 - **Greater Capacity-**1' Additional Side Rail Height Available (@ water level 6-8 yards)
 - Rear Gate Option: Barn Door or Knife Gate
 - Tarp: Electric Cable or Swing Arm System
 - Liner: HMW or Asphalt Rated

CAS® Slingers do the work, so you don't have to!

